

Pace Setter DECEMBER 2012

“After Holiday Party” Kentucky Region PCA Jan 19, 2013

The membership is invited to attend our 2012 “After Holiday Party”. The party is set for Saturday evening, January 19th. It will be held at the Lake Forest Lodge party room like last year.

The cost will be \$10 per person. At this time we’re **limited to the first 50 people signing up ahead of time**. There is no pay at the door. If more than 50 pay before Jan 18th we will accommodate them. The food will be from Mark’s Feed Store with appetizers and holiday drinks included. If you wish to bring a holiday desert to share with everyone that would wonderful. We’ll have music and door prizes. If anyone wishes to donate a door prize, please let us know. The more the merrier!

Please mail your RSVP along with your check to:

After Holiday Party KyPCA
PO Box 35341
Louisville KY 40232

(Make check payable to: The Kentucky Region PCA)

Questions:
Richard Darnell
502-889-8120



KY PCA Website

www.kypca.org

Forums & E-Mail List

Stay informed and participate! Join the KYPCA forums & mailing list and be notified of upcoming events, club news, and membership information.

Remember, it's your participation as a member that makes the club successful.

Please visit the below website and sign-up today!

<http://forums.kypca.org/>

Current Forums List:

- **Let's Go Driving**
- **Want To Sell**
- **Want To Buy**
- **Recycler**
- **Tech Talk**
- **Make It Shine**
- **Track & DE**
- **Autocross**
- **Club News**
- **Off Topic**
- **Member Rides (upload your photos)**

www.kypca.org/news

(club activities, meetings, or general announcements from KY Region PCA, the latest issue of the Pacesetter (our monthly newsletter), announcements of new models, racing news)

www.kypca.org/information

(club specific documents, upcoming club events, frequently asked questions, mailing list sign-up, Web Links)

www.kypca.org/media

(photos and videos from club events (member submitted or just something we think is really cool and Porsche related))

Having trouble viewing the kypca.org website? Do you have a suggestion on how we can improve it? Please send any feedback you might have to feedback@kypca.org.

2012 KENTUCKY REGION PCA OFFICERS & BOARD MEMBERS

President:

Steve McCombs

2603 Foxy Poise Rd.
Louisville, KY 40220
(502) 558-0306
shmc930@hotmail.com

Vice President:

Jeremy Miller

2409 Running Brook Trail
Fisherville, KY 40023
(502) 396-9111
jers993@msn.com

Secretary:

Chad Rainey

3904 Chesley Martin Dr
Louisville Ky 40299
502 439-8251
raineycd@hotmail.com

Treasurer:

Richard Darnell

4100 Narcissus Dr.
Louisville, KY 40219
(502) 889-8120
rdarnell@ayebblink.com

Membership:

Gene Hoffman

1910 Duker Ave
Louisville, KY
(502) 435-4981
rgenehoffman@gmail.com

Activities Chair:

Steven Rountree

(502) 386-3001
smr9463@insightbb.com

PaceSetter Editor:

Belinda Schweinhart

10712 Sun Ridge Rd.
Goshen, KY 40026
(502) 228-9725
article@kypca.org
belinda@lowcarbrecipes.com

Board Members:

Andy Daugherty

(2012-2013)
1283 Farmdale Ave.
Louisville KY 40213
(502) 744-9343
dobie356@msn.com

Mark Lichtefeld

(2012-2013)
5726 Moser Farm Rd.
Prospect, KY 40059
(502) 412-4185
marke@lichtefeldinc.com

Jason Miller (2011-2012)

6607 Westwood Way
Crestwood, KY 40014
(502) 253-5704
millermd@insightbb.com

Past President:

Tony Proasi

1522 McKay Ave.
Louisville, KY 40213
(502) 751-1126
wagwerks@msn.com

Website Chair:

Mark Bos
mbos@bluegrass.net

SW KY Area Rep.

Richard Hughes

981 Dunbarton Ave.
Bowling Green, KY
42104
(270) 991-4848
jrhughes47@hotmail.com

2012 KY Region PCA Calendar

www.kypca.org

Current Events!!	JANUARY	FEBRUARY	MARCH
<p>*****</p> <p>NEW LOCATION AGAIN!!</p> <p>*****</p>	APRIL	MAY	JUNE
<p>December 11, 2012 Membership Mtg. Mellow Mushroom Pizza Time: 7:00 PM Contact: Steve McCombs (see page 12)</p>	JULY	AUGUST	SEPTEMBER
<p>December 15, 2012 Breakfast Social Frisch's Poplar Level Road Time: 9:00 AM- ??? (see page 6)</p>			
<p>NOTES: Contact Information can be obtained in the newsletter on Page 2.</p> <p>All events are subject to change due to weather and availability.</p>	OCTOBER	NOVEMBER	DECEMBER
			<p>10th—Membership Mtg. (see page 12)</p> <p>15th—Breakfast Social (see page 6)</p>
		<div style="border: 1px solid black; padding: 5px;"> <p>“After Holiday Party” Jan 19, 2013 (see page 1)</p> </div>	



Diagnostically speaking, there is no substitute.

The best equipment. And the best minds trained to use it. These are your Porsche certified technicians. Dedicated to Porsche vehicles above all else, they must complete over 80 hours a year training in the latest diagnostic technology and techniques. You'll also take comfort knowing all Porsche genuine parts are factory-backed for two years when installed by your authorized dealer. Better still, there is no substitute for having your vehicle serviced by professionals who not only know Porsche, but live Porsche every day.

Porsche Certified Service.

Blue Grass Motorsport
4720 Bowling Blvd.
Louisville KY 40207
502-515-5881

Porsche recommends **Mobil 1**



PORSCHE



Lichtefeld Incorporated

A Construction and Development Company



Office
Retail Centers
Medical
Churches
Manufacturing
Warehouse
Banks
Schools



Let Lichtefeld Handle the Business of Building
While You Handle the Building of Your Business

Total Turn Key Design/ Build Construction and Leasing. Call for Your Free Estimate/Consultation

www.Lichtefeldinc.com

Contact: Mark Lichtefeld

502-589-4777

To maintain machines like these...



... Takes skills like ours.

2 locations Middletown 245.3414 Bowman Field 452.9721 www.steinauto.com



Saturday Morning Breakfast Social

The breakfast club continues to be a good thing despite the "day off early hour". Most of the turnout is made up of members with older Porsches. 356's, 911's, 912's, 914's & 944's grace the parking lot with a Boxster or a Cayman in the mix to look after the older rides. The owners are really hands-on people with their cars. The conversations over coffee are always geared to what they have done themselves to keep these senior Porsches in first class condition. No dealership repairs for this bunch! The Saturday breakfast participants really are the "Patrons Of Older Porsches".

The menu at Frisch's is extensive, the breakfast bar is wonderful and the coffee is just right. The early time allows everyone time to make it to Cars n Coffee in the East End without rushing. This is a fun bunch of members, come join us. We would enjoy seeing all of you there.

No reservations required, just show up.

Contact Edgar Smiley at 502.939.3595 (cell) or deKYblugras@aol.com

Worried about IMS failure?



We have the **IMS Guardian** DIY Kit in stock, ready to ship. The only engine pre-failure warning system on the market for M96/M97 Porsche engines

The Kit includes a step-by-step DVD installation guide

Call 954.385.0330 **technolab/PEDROGARAGE**
Florida Pre-Purchase Inspections (PPI)

FREE DIY tutorials and technical info on our website.

technolab
PEDROGARAGE

We also offer: ECU Tuning, Bored TBs, HID/LED Performance Parts, Brake Caliper Restoration & Painting, AX & DE Magnetic Bras and Numbers, much more.

954.385.0330 • www.PedrosGarage.com

PACESETTER ADVERTISING RATES

Classified Ads for 'The Mart' are published at no cost to PCA members for 3 months and at nominal cost to non-members. Send copy for ads to the PaceSetter Editor.

Commercial Rates: 1/4 Page \$130, 1/2 Page \$250, Full Page \$500, per year. Quarterly terms are available but require advance payment.

Business card ads are accepted from Kentucky Region members only at \$65 per year. Mail your card and a check made payable to Kentucky Region PCA, to the Pacesetter Editor.

Central Indiana PCA
Calendar
www.cirpca.org



CKR Solo Schedule

Central KY Region SCCA
Schedule is at: www.ckrscca.org

THE MART

The Mart Rules

The Mart Ads are free to all PCA members. **It will appear for TWO issues and can be relisted by contacting the newsletter editor.**
All ads must be car related.

To place an advertisement in "The Mart" contact the PaceSetter editor.

Cars for Sale

2001 Porsche Twin Turbo; 81,XXX miles; new clutch, Michelin Pilot Sports; Evoms 750 kit; never been on track; have all records; excellent condition; \$39,500. Contact David Sarten 270-748-5098 or disarten@ken-tennwireless.com



Welcome New Members!!

October 2012

Bowling, Scott D. & Melanie
Louisville, KY 40214
2012 911 Black

Chubinidze, Omari
Goshen, KY 40026
1995 Carrera

Daugherty, Jonathan S.
Louisville, KY 40291
1971 911 Yellow
Transfer from: Bluegrass (BGS)

Glazer, Mark L. & Susan
Prospect, KY 40059-9461
2008 Cayman Red

Howard, Robert S.
Kirksey, KY 42054
1999 Boxster Blk
Transfer from: Bluegrass (BGS)

Jacobs, Tony & Nick Fratticcioli
Louisville, KY 40245
2007 Cayman S Black
Transfer from: Schattenbaum (SCH)

Newman, Teri
Louisville, KY 40202
Transfer from: Longhorn (LHN)

Ricker, Karl L. & Teri Newman
Louisville, KY 40202
1983 911 White
Transfer from: Longhorn (LHN)

Summerfield, Mike S.
Louisville, KY 40204
2007 911 GT3 Black

PCA Anniversaries!!

Octoberber 2012

1977 Wilson, David & Denise
1989 Wood, L E. & Gayle
1998 McHugh, Peter & Patrick McHugh
1999 Hagans, Frank & Donna
1999 McCombs, Steve H.
2000 Fultz, Dan L.
2001 Brodsky, Mark A. & Sandra
2001 Wilson, Greg
2002 Smiley, Edgar & Lucas Smiley
2008 Hoagland, Lee E. & Julia M.
2009 Innes, Matt R. & Lucy
2010 Martin, Kenneth T.

The Battery

Published in the October 2010 issue of “*Die Porsche Kasette*”

Our car’s batteries use technology invented in 1860 by Gaston Planté and they are of the 12 volt, lead-acid, starting type.

The traditional 12 volt lead acid battery is actually made up of six identical 2 volt cells. Each cell is made up of lead plates of different composition, immersed in dilute sulphuric acid.

Lead dioxide (PbO_2) plates are connected to the positive terminal of the cell and react with the sulphuric acid (H_2SO_4) to form lead sulphate and give up electrons.

The negative terminal of the cell is connected to pure lead (Pb) plates which react with the sulphate ions to also form lead sulphate.

The pure lead plates supply two positive charges and are left negatively charged.

The stream of electrons passing from the lead-oxide plates to the pure lead plates is the electric current generated by the cell.

When the battery is recharged, the lead sulphate in each cell is broken down resulting in lead dioxide being redeposited onto the positive electrode, and lead being deposited onto the negative electrode.

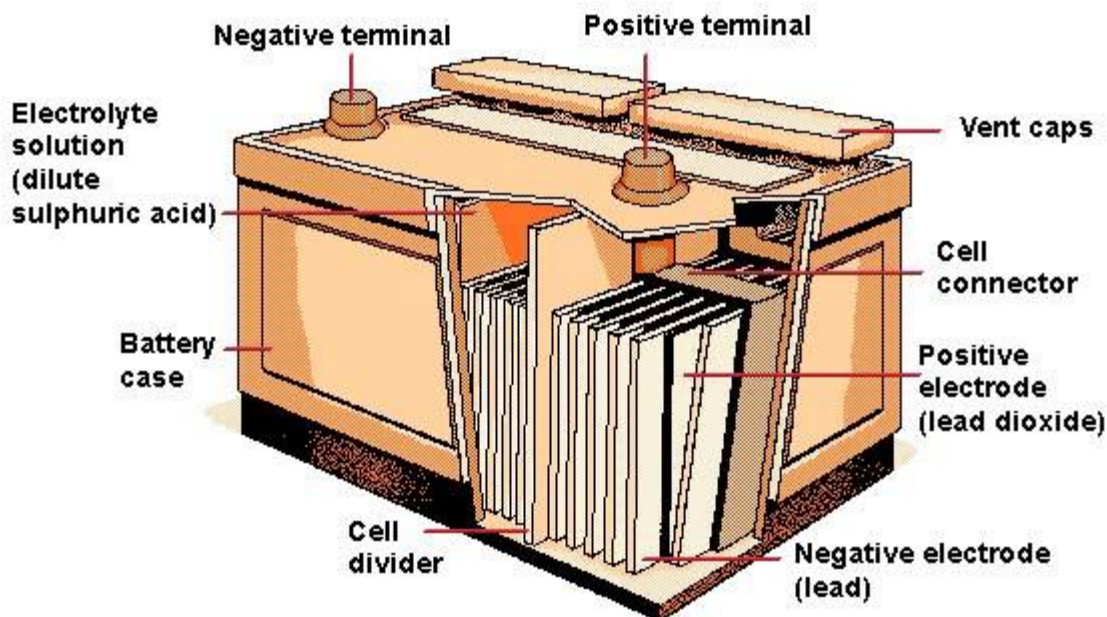

Starter batteries are made up of many thin lead plates which enable them to discharge a lot of energy very quickly which is what's required by a vehicle's starter motor which must turn over the engine in order to start it.

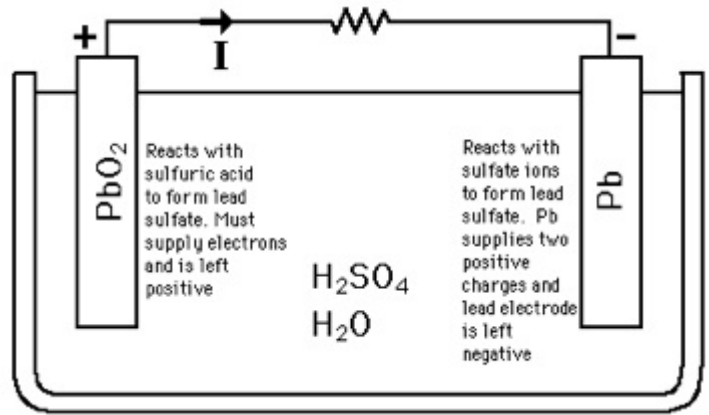

These types of batteries, like everything else, have their pros and cons.

PROs	CONs
Low Cost	Heavy and bulky
Very reliable	Charge efficiency only 70%
Tolerant to abuse	Danger of overheating during charging
Tolerant to overcharging	Not suitable for fast charging
Can deliver high current	Typical life is 300 -500 cycles
Indefinite shelf life when stored dry	Must be stored charged with electrolyte
May be on float/trickle charge for long time	Can leak corrosive acid
Many sizes and capacities available	Require ventilation
Many manufacturers worldwide	
World's most recycled product	

In order to prolong the battery's life you need to charge it immediately after use. They will last longer with partial discharge rather than a full discharge. The best charging method is a constant voltage followed by a float charge. Unfortunately a fast charge is not possible.

The vehicle's alternator is actually the battery's charger. As soon as the car's engine starts, the alternator starts sending an electric current back to the battery, which keeps it fully charged and ready for the next engine start.

When charging, be it by the vehicle's alternator or by an outside charger, the battery slowly loses water due to evaporation and therefore needs periodic maintenance. Regularly check the volume of electrolyte in each cell and top off as necessary with distilled water.

Porsches come from the factory with Moll batteries in place. Depending on conditions and use, a battery should last between 4 and 7 years.

When replacing you can replace with another OEM Moll battery, or you can opt for any of a myriad of suppliers which offer much cheaper alternatives.

Be sure that you install the correct size, not only physically, but also electrically.

Make sure that the new battery has close to the same starting capacity measured in CCA (cold cranking amps). The correct base and shell size will allow for the secure placement as well as the correct position of the terminals so that the car's battery wires can reach them.



There is newer battery technology on the market (Absorbed Glass Matt - AGM) which requires no maintenance and has eliminated quite a few of the cons of the traditional lead-acid battery, such as: better weigh-to-power ratio, can be placed in any position (even upside down), higher tolerance to vibration and shock, will not leak or out gas, needs no vent, is completely sealed, has a lower rate of self-discharge, and lasts longer.



In these AGM type batteries the lead plates and the separator are wound and tightly compressed into a cell tube so they can't move, shed, or break even in severe shock and vibration applications and the separator, which is an absorbent glass matt, holds the electrolyte like a sponge so it can't spill. Their main drawbacks are higher cost and unique shape which needs special adaptors and plates to safely mount in our vehicles.

If you are storing a battery for an extended period, it is recommended that it be stored in a cool, dry place, off the floor and connected to a smart charger such as the CTEK Multi US 3300 which will apply a constant voltage until the battery fully charges, then maintains a float or trickle charge to keep it at its peak.



If you want to find out more about batteries and how to make them last longer in your Porsche, please visit our website: www.PedrosGarage.com.

Happy Boxstering,

Pedro



technolab

Pedro P. Bonilla
Weston, FL 33327
(954) 385-0330
ppbon@aol.com
Pedro@PedrosGarage.com
www.PedrosGarage.com
www.PedrosBoard.com



- Indoor Storage
- We now Mount Tires
- Morning Shuttle Service
- Parts & Service

STUTTGART *Specialists*

4204 Poplar Level Rd.
Louisville KY 40213
502.454.5591

DECEMBER MEMBERSHIP MEETING

mellow MUSHROOM PIZZA

3920 Shelbyville Road,
Louisville, KY 40207
Phone: 502-409-6874 (MUSH)

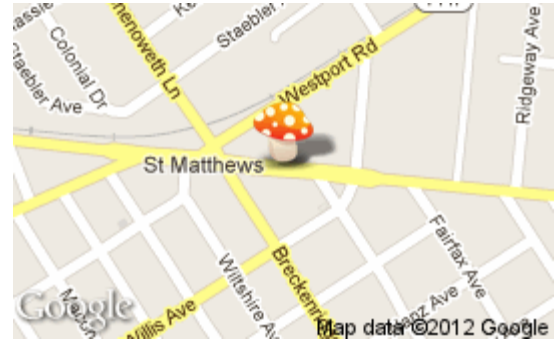

Monday
Dec. 10th
7:00 PM



Parade Tech Quiz: Do you have what it takes to score well?

PCA



Let's find out! One of the four competitive elements at the PCA Porsche Parade is the Historical and Technical Quiz. The test includes general PCA trivia as well as model specific questions. Model specific tests include: 356, 914/914-6, 924/944/968, 928, early 911, mid-year 911, 964/993, 996/997, Boxster/Cayman, and Cayenne/Panamera. We thought we'd share this year's mid-year 911 test for e-Brake news readers to "enjoy." Good luck! Click on the words for the [Test](#) and [answer sheet](#).

Mark your calendars for next year's Parade in Traverse City, Mich., on June 23-29.